

TCBENCH96

0.09x Telecentric Optical Bench Kit

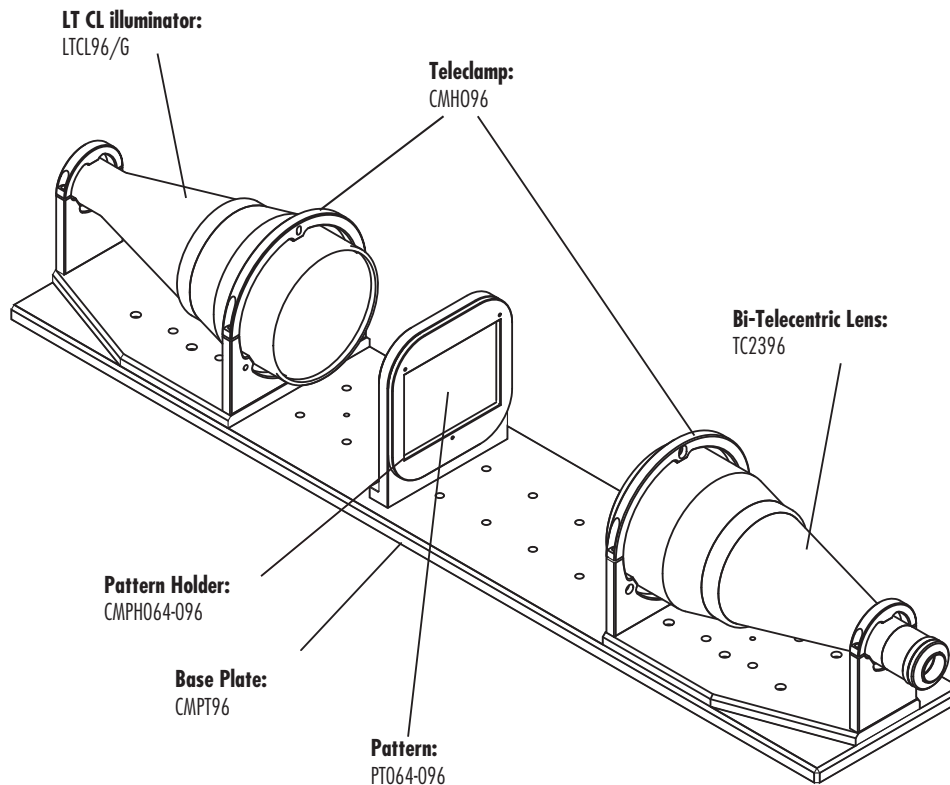

part number	TCBENCH96	
Magnification		0,093
Field Of View	(mm x mm)	
with 1/2" (6,4 x 4,8) detector		68,6 = 51,4
with 1/1.8" (7,13 x 5,37) detector		76,3 = 57,5
with 2/3" (8,8 x 6,6) detector		94,2 n.a. 70,7
Measurement Accuracy	(micron)	70,0
Measurement Accuracy	(%)	0,07%
Field Depth	(mm)	94,00
CTF @70 lp/mm	(%)	> 50
Mount		C
Length	(mm)	1053,0
Width	(mm)	206,5
Height	(mm)	185,0
Weight	(g)	15300

Rev No.	Description	Date	Name
A	New Part	22/10/09	N. Santini

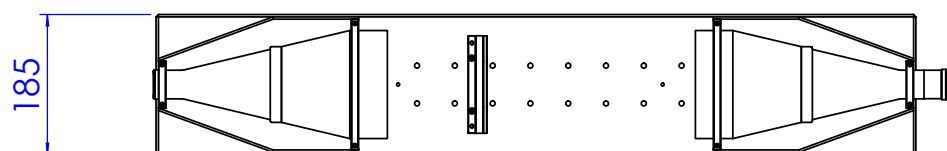
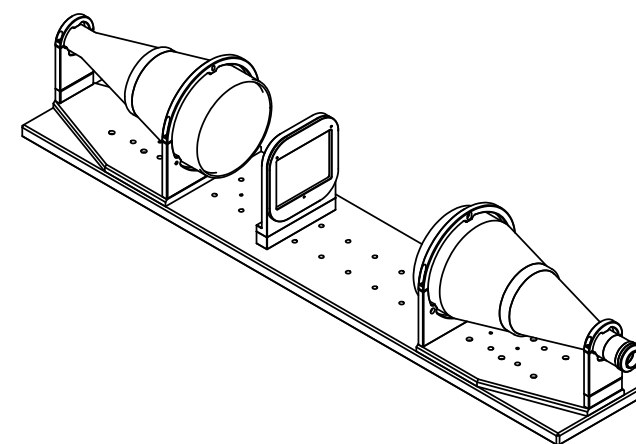
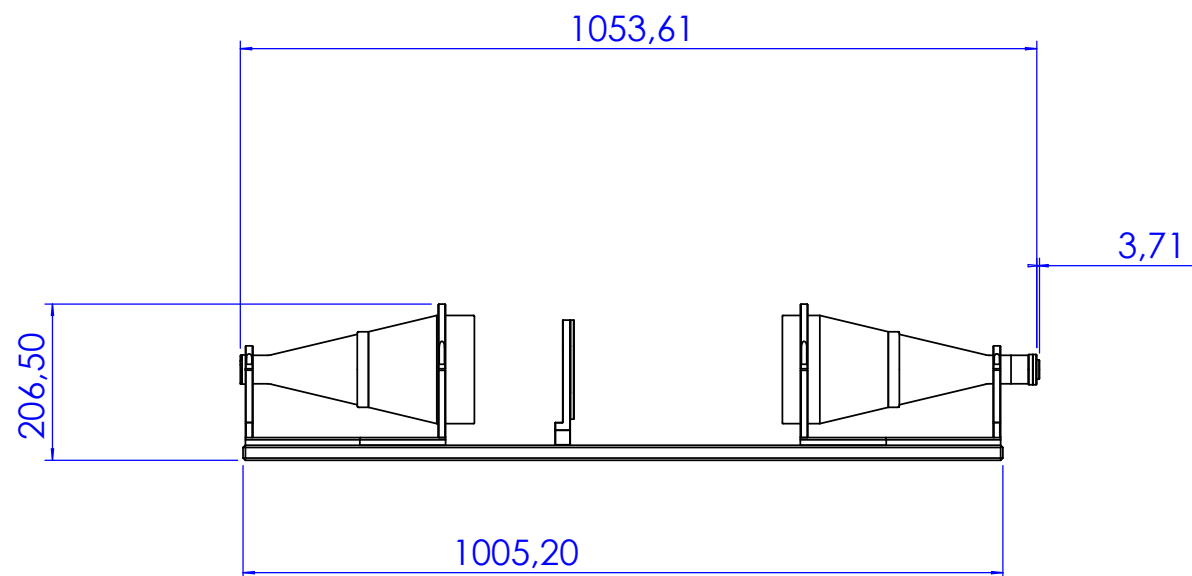

Material	N.A.			Mass	15362 g	Scale	1:10	
Surface treatment	N.A.			Project-Prod.item/Instrument TCBENCH96				
Geometrical tolerance (ISO 2768-2)			Class	K	Undimensioned bevels			
Linear tolerance (ISO 2768-2)			Class	m	1x45°			
0,5 ±3	>3÷ 6	>6÷ 30	>30÷ 120	>120 ±400	>400÷ 1000	>1000 ±2000	>2000 ±4000	
					Undimensioned radii			
±0.1	±0.1	±0.2	±0.3	±0.5	±0.8	±1.2	±2	
				Date	Name	Drawing No.		
				Designed	22/10/09	N. Santini	19107-0-A	Sheet 1/1
				Draw	22/10/09	N. Santini		
				Checked	X	C.Sedazzari	Reproduction forbidden without specific authorization	
OPTO ENGINEERING S.r.l. - 46100 Mantova Italy - Via Cremona, 29/2 - Tel. +39 0376 263565 - e-mai: info@opto-engineering.com - http://www.opto-engineering.com								