

TCBENCH64

0.14x Telecentric Optical Bench Kit

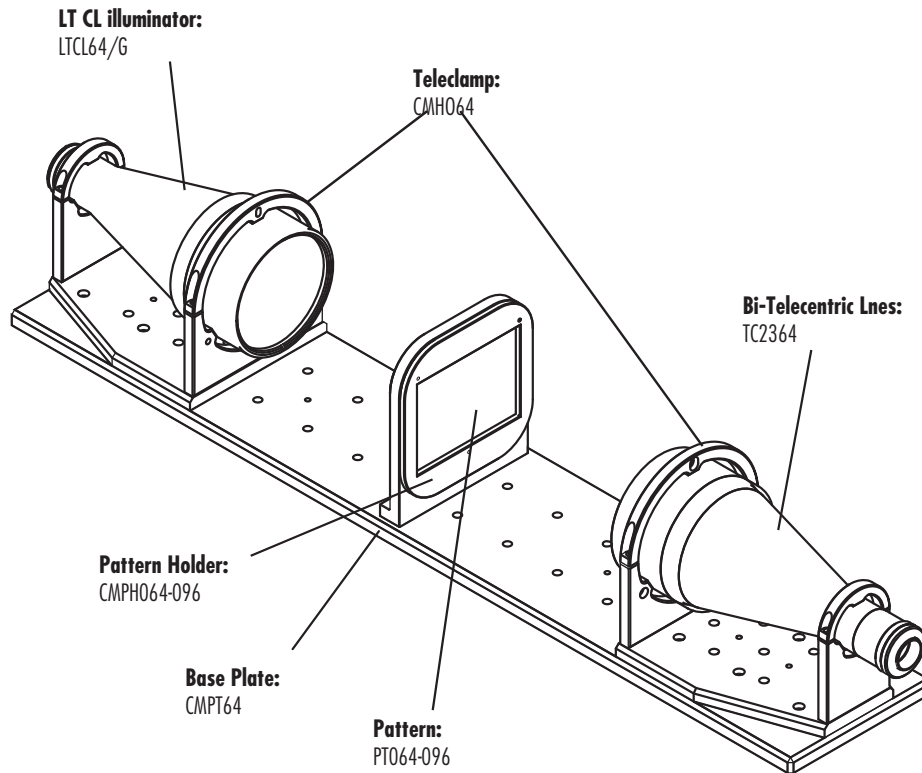

part number		TCBENCH64
Magnification		0,138
Field Of View	(mm x mm)	
with 1/2" (6,4 x 4,8) detector		46,5 x 34,9
with 1/1.8" (7,13 x 5,37) detector		51,8 x 39,0
with 2/3" (8,8 x 6,6) detector		64,0 x 48,0
Measurement Accuracy	(micron)	40,0
Measurement Accuracy	(%)	0,06%
Field Depth	(mm)	43,00
CTF @70 lp/mm	(%)	> 66
Mount		C
Length	(mm)	845,0
Width	(mm)	143,0
Height	(mm)	160,5
Weight	(g)	8700

Rev No.	Description	Date	Name
A	New Part	22/10/09	N. Santini

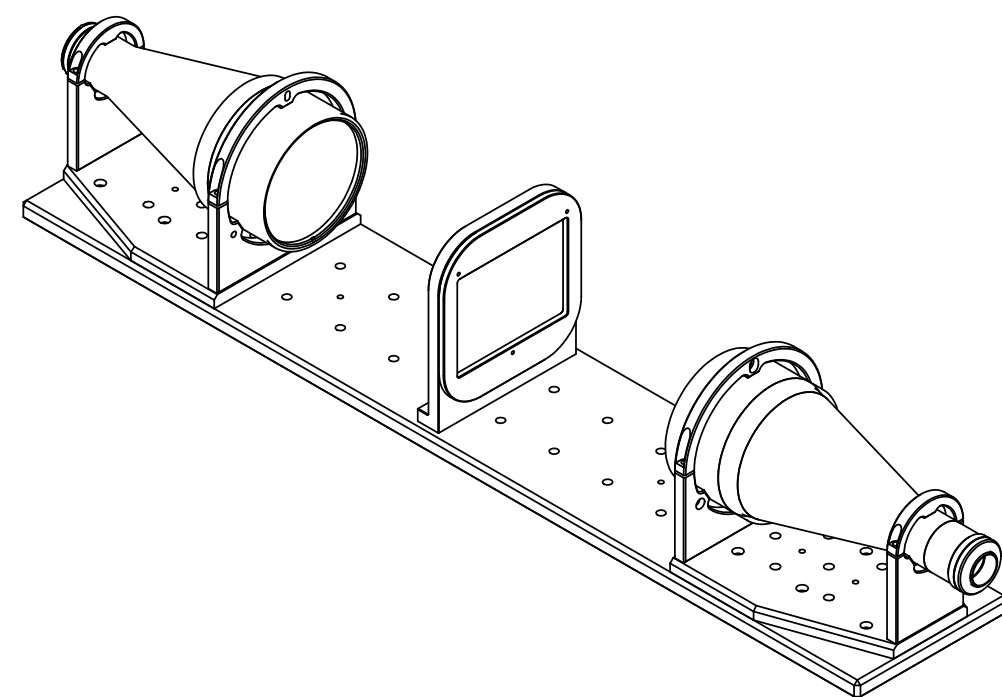
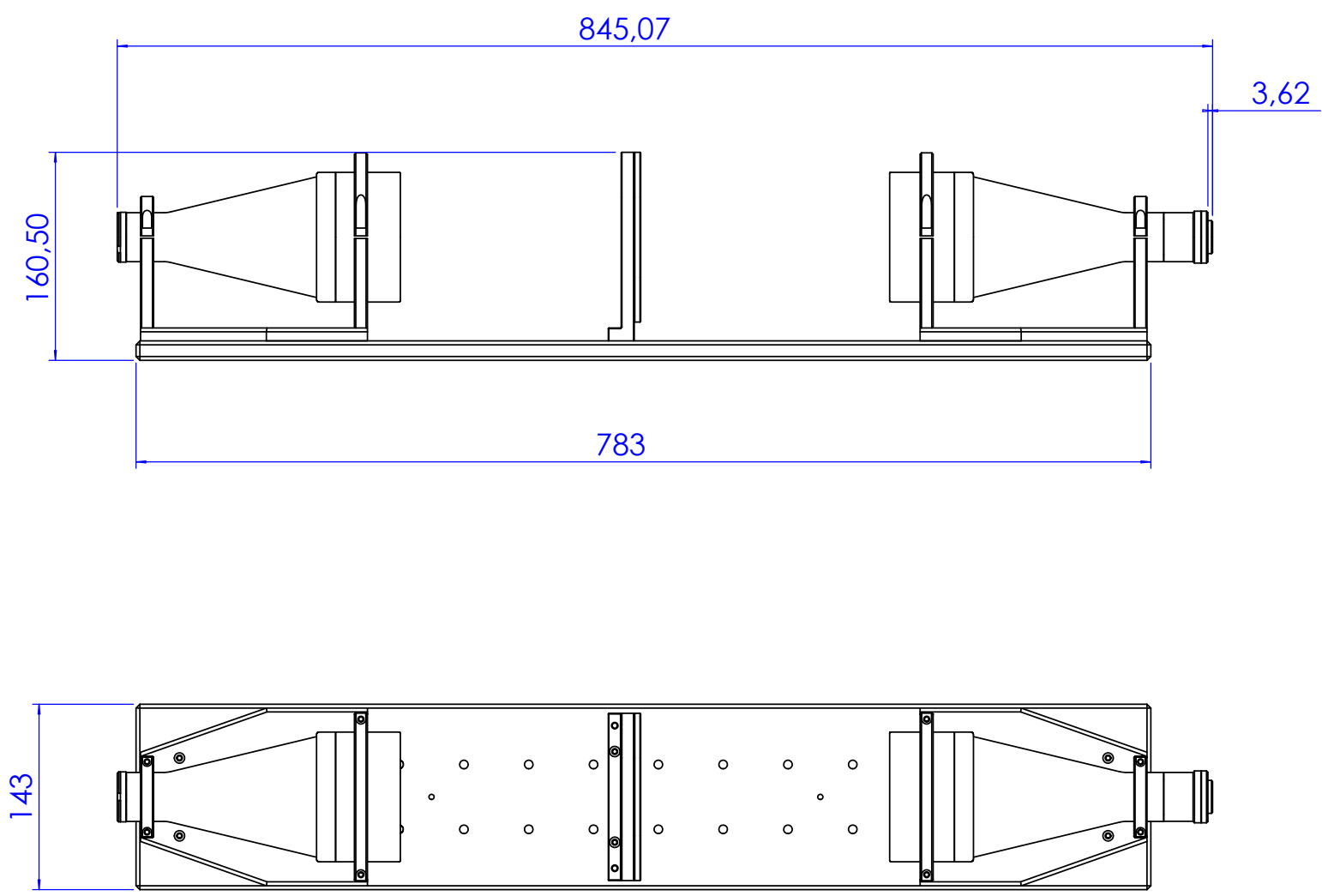

Material	N.A.			Mass	8670 g	Scale	1:5
Surface treatment	N.A.			Project-Prod.item/Instrument		TCBENCH64	
Geometrical tolerance (ISO 2768-2)			Class	K	Undimensioned bevels		
Linear tolerance (ISO 2768-2)			Class	m	1x45°		
0,5	>3÷	>6÷	>30÷	>120	>400÷	>1000	>2000
±3	6	30	120	±400	1000	±2000	±4000
±0.1	±0.1	±0.2	±0.3	±0.5	±0.8	±1.2	±2
Undimensioned radii			R 0.5			Description	
						TCBENCH64	
			Date	Name	Drawing No.	Sheet	
			Designed	22/10/09	N. Santini	19105-0-A	
			Draw	22/10/09	N. Santini		
			Checked	X	C.Sedazzari		
			Reproduction forbidden without specific authorization				1/1
OPTO ENGINEERING S.r.l. - 46100 Mantova Italy - Via Cremona, 29/2- Tel. +39 0376 263565 - e-mai: info@opto-engineering.com - http://www.opto-engineering.com							

