

BI-TELECENTRIC LENS FOR DETECTORS UP TO 2/3"



Part Number		TC 23 192
Magnification		0,046 +/- 3%
Field Of View	(mm x mm)	
with 1/4" (3,6 x 2,7) detector		78,7 x 59,0
with 1/3" (4,8 x 3,6) detector		104,9 x 78,7
with 1/2" (6,4 x 4,8) detector		139,8 x 104,9
with 1/1.8" (7,13 x 5,37) detector		155,7 x 117,3
with 2/3" (8,8 x 6,6) detector		192,3 x 144,2
Working Distance	(mm)	531,0 +/- 16
Working F-number		8
Telecentricity	(degree)	< 0,08
Distortion	(%)	<0,08
Field Depth	(mm)	320,0
CTF @70 lp/mm	(%)	> 35
Image side N.A.		0,0620
Object side N.A.		0,0028
Mount		C
Length	(mm)	622,3
External diameter	(mm)	260,0
Weight	(g)	11400

ACCESSORIES AND OPTIONS:



Collimated/Telecentric illumination:
compatible with LTCL192 illuminator;
green light suggested.



Coaxial illumination:
not available.



Back Light illumination:
compatible with LTBK192 illuminator.



Clamping Mechanics:
use the built-in holed flange to mount
the lens.



Direct illumination:
not available.



Filters:
filters can be inserted in the rear part
of the lens, by means of TC Filter Kit.

Rev No.	Description	Date	Name
A	First light	31/01/07	A.Vismara

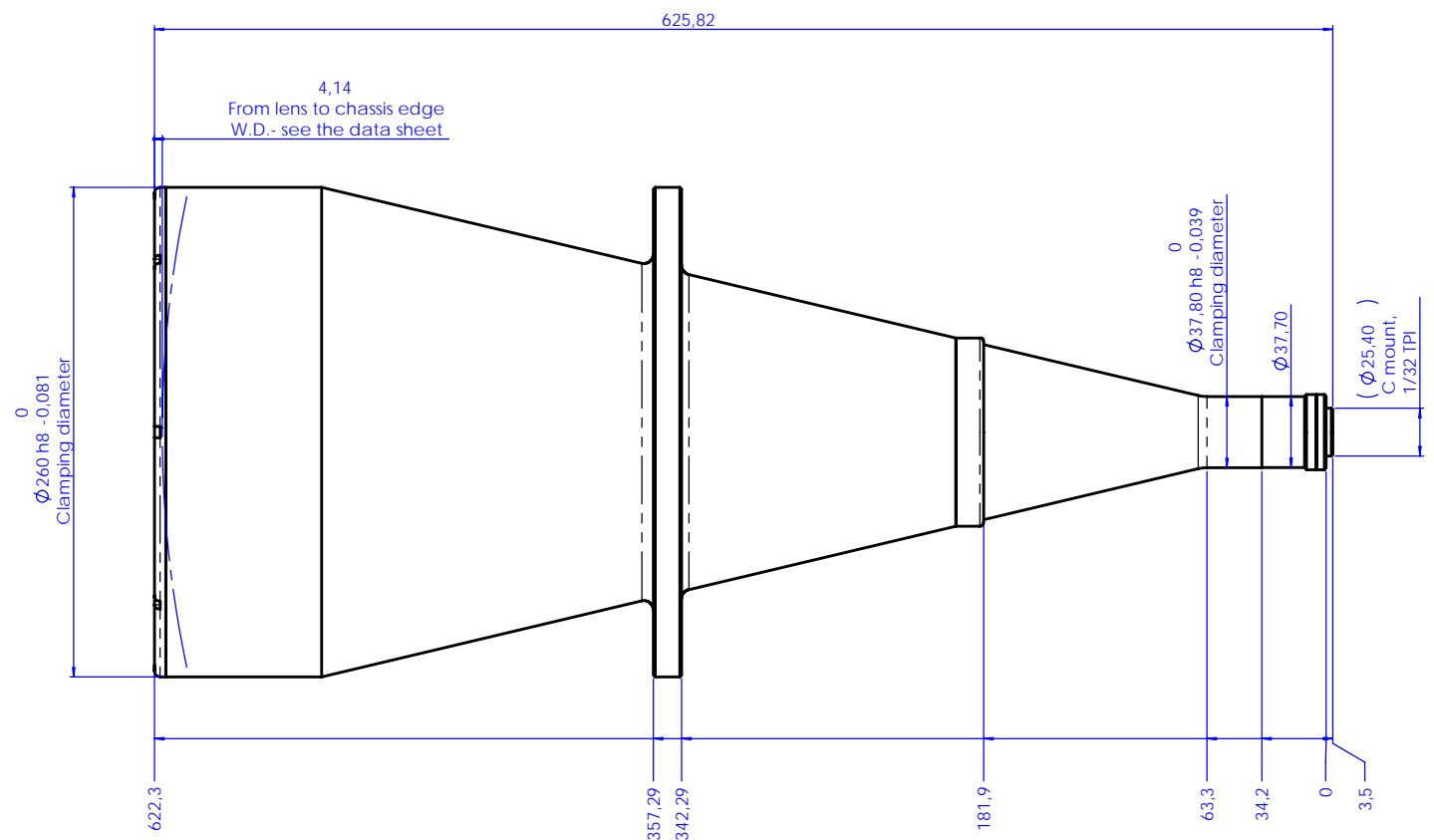
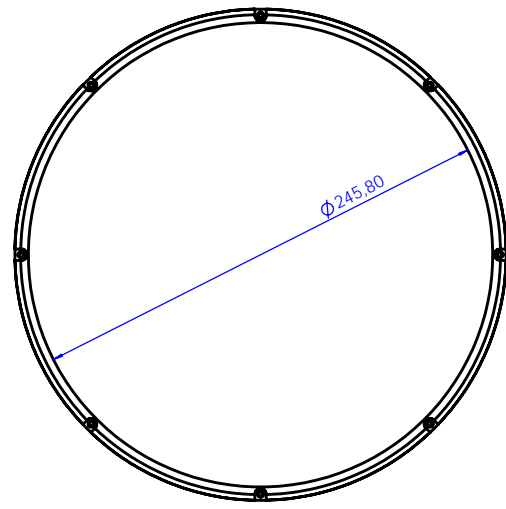
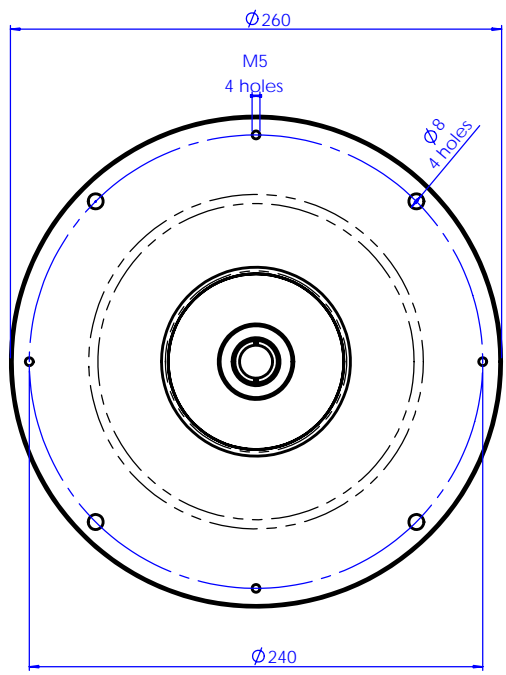

Material	N.A.	Mass	11.4 kg	Scale	1:2
Surface treatment	N.A.	Project/Prod./Item/Instrument	Telecentric lens 23 192		
Geometrical tolerances (ISO 2768-2)		Class	K	Undimensioned Bevels	1x45°
Linear tolerance (ISO 2768-2)		Class	m	Undimensioned Radii	R 0.5
0.5	>3-	>6-	>30-	>120	>400-
-3	6	30	120	400	1000
±0.1	±0.1	±0.2	±0.3	±0.5	±0.8
		Class	m	±1.2	±2
		Date	Name		
		Designed	31/01/07	A.Vismara	
		Draw	31/01/07	A.Vismara	
		Checked	x	C.Sedazzari	
		Drawing No.		Sheet	
		02551-0-A		1/1	
www.opto-engineering.com					
OPTO ENGINEERING S.r.l. - 46100 Mantova Italy - Via Cremona, 28 - Tel/Fax +39 0376 229585 - e-mail: info@opto-engineering.com - http://www.opto-engineering.com					