

## 360° VIEW OPTICS

## MICRO-POLYVIEW

**Micro-PolyView** is a 3D, multi-image lens designed to completely measure and inspect objects whose dimensions range from 1 to 10 millimeters, such as electronic components, solder paste and micro-mechanics.

Six different lateral views are provided by an array of mirrors interfaced to a bi-telecentric lens; the top of the object is directly imaged at the center of the field of view.

The lateral views feature exactly the same magnification and the images remain in perfect focus even when the object is displaced from its nominal position.

All the views can be used to precisely measure the dimension of components from different angles.

**Micro-PolyView** integrates LED illumination with the most appropriate lighting geometry for this optical configuration.

# 3D measurement and imaging of small parts

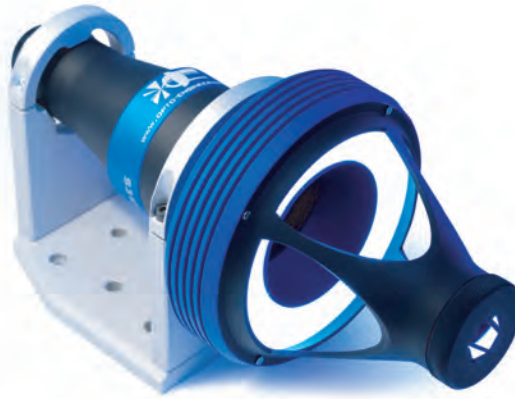

### KEY ADVANTAGES

- 1 Small parts lateral imaging:** inspection of objects whose size ranges from 1 to 10 mm
- 2 Measurement capability:** the top and the lateral views show the same magnification
- 3 High field depth:** part decentering can be tolerated without significant defocusing

part number		PCMP012	PCMP023
detector size		1/2"	2/3"
max inspection height with diameter 2.5 mm		6	6
max inspection height with diameter 5 mm		4,5	4,5
max inspection height with diameter 7.5 mm		3	3
max inspection height with diameter 10 mm		1	1
wavelength range	(nm)	450 .. 650	450 .. 650
working distance	(mm)	1,5 .. 5	1,5 .. 5
CTF @ 50 lp/mm	(%)	> 40	> 40
f-number		8	8
diameter	(mm)	119	119
length	(mm)	262	262
weight	(g)	980	980
mount		C	C



## MICRO-POLYVIEW

## 360° VIEW OPTICS



**Mechanical components inspection:** thread integrity, pitch and diameter can be verified and measured.

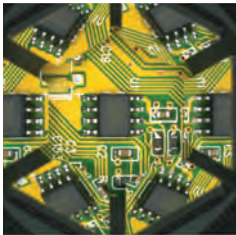

**SMD component inspection:** integrated circuit position, rotation, pin integrity and bonding can be checked.

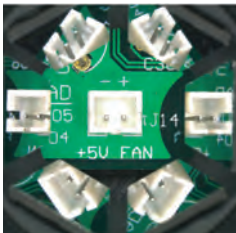

**Electronic connector checking:** presence/absence, alignment and length of pins can be precisely measured.

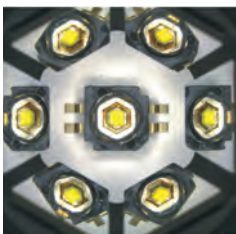

**LED quality control:** lens scratches, die centering and correct wiring can be inspected and measured.

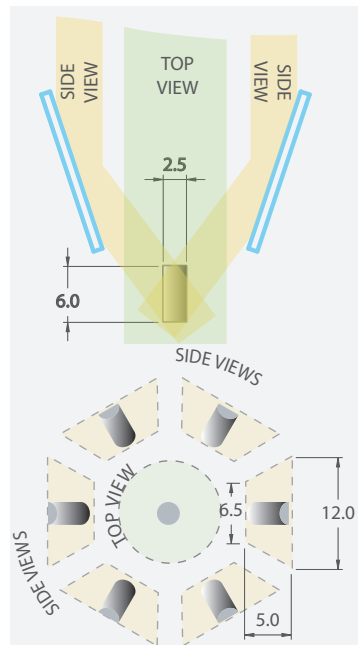
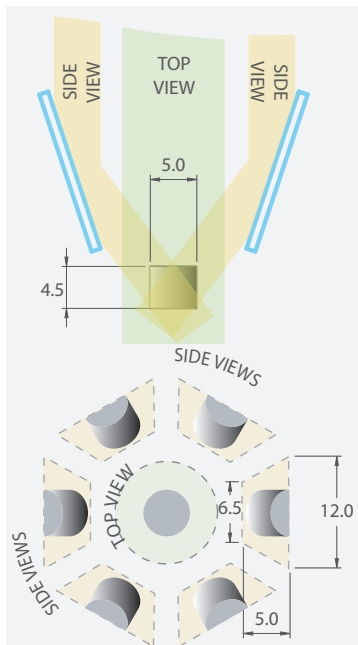
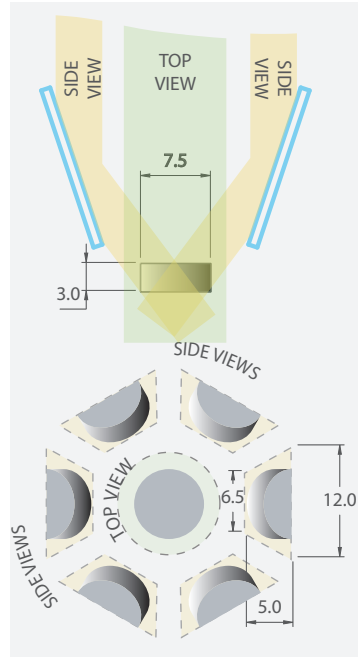
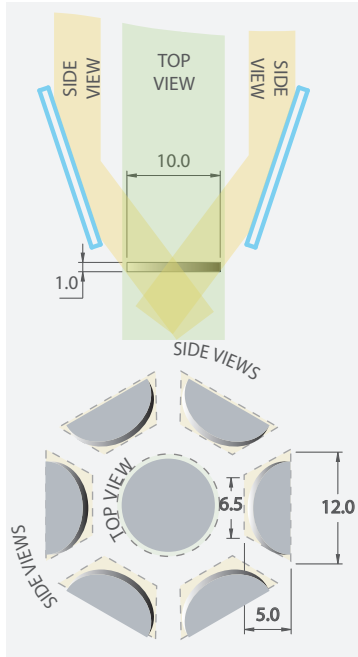

The suggested working distance ranges from 1.5 to 7.5 mm. The best focusing can be achieved by adjusting the number of spacers in the C-mount interface or by vertically positioning the illuminator+mirror assembly.

The image orientation phase can be adjusted by simply rotating the mirror cage or the whole assembly.

The top and side views show exactly the same magnification; however the side views appear to be compressed because of the perspective angle. Thanks to telecentric imaging such compression is purely linear and therefore very easy to compensate.

Customized versions available with:

- **different number of views**
  - **different mirror inclination angles**
  - **asymmetric or special mirror arrays**
- are possible and easily manufacturable.