



LT SP SERIES

LED SPOT ILLUMINATORS

UV  and  IR
versions available



LT SP FOCUSABLE SPOT LED ILLUMINATORS are one of the most advanced products in the field of imaging illumination.

Developed by means of Opto Engineering's expertise in the field of show lighting, LT SP illuminators can generate incredibly bright, homogeneous and sharply delimited light spots.

Once the illuminator is placed, the focus can be adjusted in order to obtain a very evenly illuminated spot with a very sharp circular edge.

Built-in micro-switching electronics ensure illumination stability active control and current limitation; the LED source and electronics can be easily replaced or interchanged by the user.



Part Number	Light Colour	Irradiance/Illuminance		
		@ 100 mm	@ 200 mm	@ 300 mm
VIS 1W SPOT ILLUMINATORS:				
LTSP36/R	red lighth	9 klux	2 klux	1 klux
LTSP36/G	green light	9 klux	2 klux	1 klux
LTSP36/B	blue light	5 klux	1 klux	0,5 klux
LTSP36/W	white light	9 klux	2klux	1 klux
VIS 3W SPOT ILLUMINATORS:				
LTSP3W/R	red lighth	24 klux	6 klux	3 klux
LTSP3W/W	white light	24 klux	6 klux	3 klux
UV 1W SPOT ILLUMINATORS:				
LTSP36/UV365	UV, 365 nm	1,6 mW/cm ²	0,4 mW/cm ²	0,2 mW/cm ²
LTSP36/UV385	UV, 385 nm	4,8 mW/cm ²	1,2 mW/cm ²	0,5 mW/cm ²
LTSp36/UV405	UV, 405 nm	6,7 mW/cm ²	1,7 mW/cm ²	0,7 mW/cm ²
IR 1W SPOT ILLUMINATORS:				
LTSP36/IR890	IR, 890 nm	7,6 mW/cm ²	1,8 mW/cm ²	0,8 mW/cm ²
LTSP36/IR940	IR, 940 nm	7,6 mW/cm ²	1,8 mW/cm ²	0,8 mW/cm ²

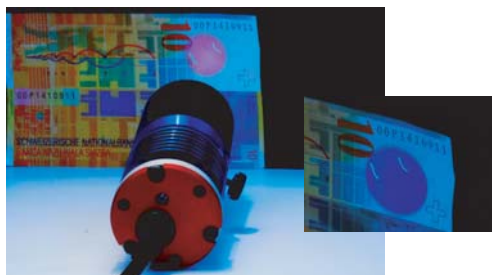

Example of UV illumination: fluorescent features of banknotes.

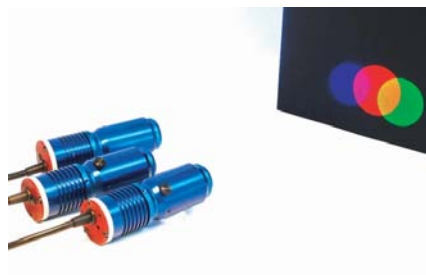

Multiple colours available: precise colour mixing is possible.

Advantages of this technology:

- high illuminance homogeneity
- high optical power
- only the target is illuminated
- distant objects can be illuminated
- directional illumination.

Some Successful Applications:

Industrial Microscopy Illumination



Inclusions in glass and liquids



Print control and Colour measurement

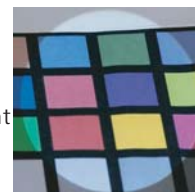

Electronic components inspection



Labels and Barcode reading



Surface defects enhancement



LT SP SERIES



SPOT DIMENSIONS:

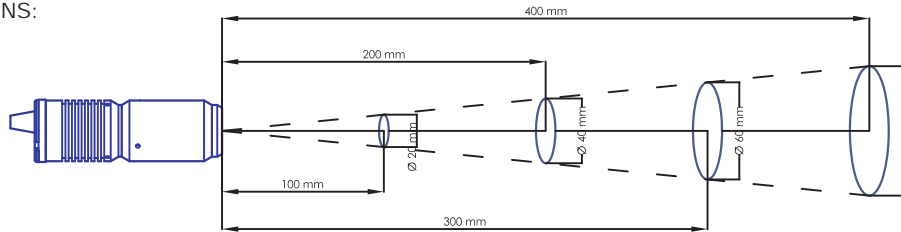

LED TYPICAL SPECTRUM:

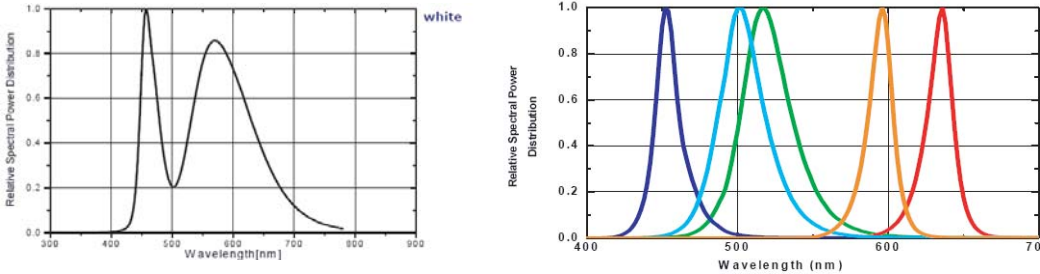

- /UV365 version: peak emission wavelength 365 nm, optical bandpass +/- 20 nm FWHM (class IIIb LED product)
- /UV385 version: peak emission wavelength 385 nm, optical bandpass +/- 20 nm FWHM (class IIIb LED product)
- /UV405 version: peak emission wavelength 405 nm, optical bandpass +/- 30 nm FWHM (class IIIb LED product)
- /IR890 version: peak emission wavelength 890 nm, optical bandpass +/- 30 nm FWHM (class IIIb LED product)
- /IR940 version: peak emission wavelength 940 nm, optical bandpass +/- 30 nm FWHM (class IIIb LED product)

ELECTRICAL FEATURES:

5) OPTICAL THROUGHPUT IS STABILIZED BY TUNABLE, BUILT-IN ELECTRONICS ...



These LED devices integrate built-in switching electronics which control the current flow through the LED. This ensures both high light stability and a longer lifetime of the product. The device light intensity can be tuned by removing the protection plastic cap in the rear and by screwing or unscrewing the trimmer inside.

BUILT-IN ELECTRONICS POWER RATINGS:
Voltage 12 to 24 V DC
Power Consumption < 2 watt

.. BUT YOU CAN PASS-BY INNER ELECTRONICS AND DIRECTLY DRIVE THE LED BY YOURSELF

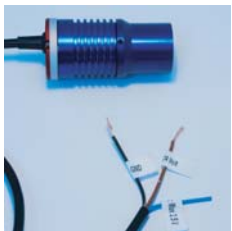

The inner circuitry can be passed-by in order to directly drive the LED inside this device thus allowing pulsed operation of this component.

For this reason, three cables are exiting the rear part of the illuminator. Instead of connecting *black* and *brown* wire leads, the *black* and *blue* wires must be connected to your power supply ensuring the below listed values are not exceeded.

LED DIRECT DRIVE RATINGS:
for /W, /B, /G and /UV versions:
Max Forward Voltage 3.5 V DC
Max Forward Current 350 mA

for /R version:
Max Forward Voltage 2.5 V DC
Max Forward Current 350 mA

for /IR890 and /IR940 versions:
Max Forward Voltage 1.6 V DC
Max Forward Current 500 mA

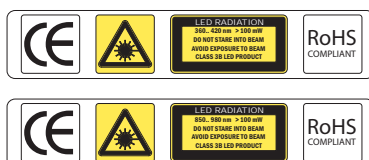

OPTO ENGINEERING S.R.L.

MECHANICAL DRAWINGS: see next pages >>

VIA CREMONA, 29/2
 46100 MANTOVA - ITALY
 TEL: +39 (0)376 263525
 FAX: +39(0)376 262432
 INFO@OPTO-ENGINEERING.COM
 WWW.OPTO-ENGINEERING.COM

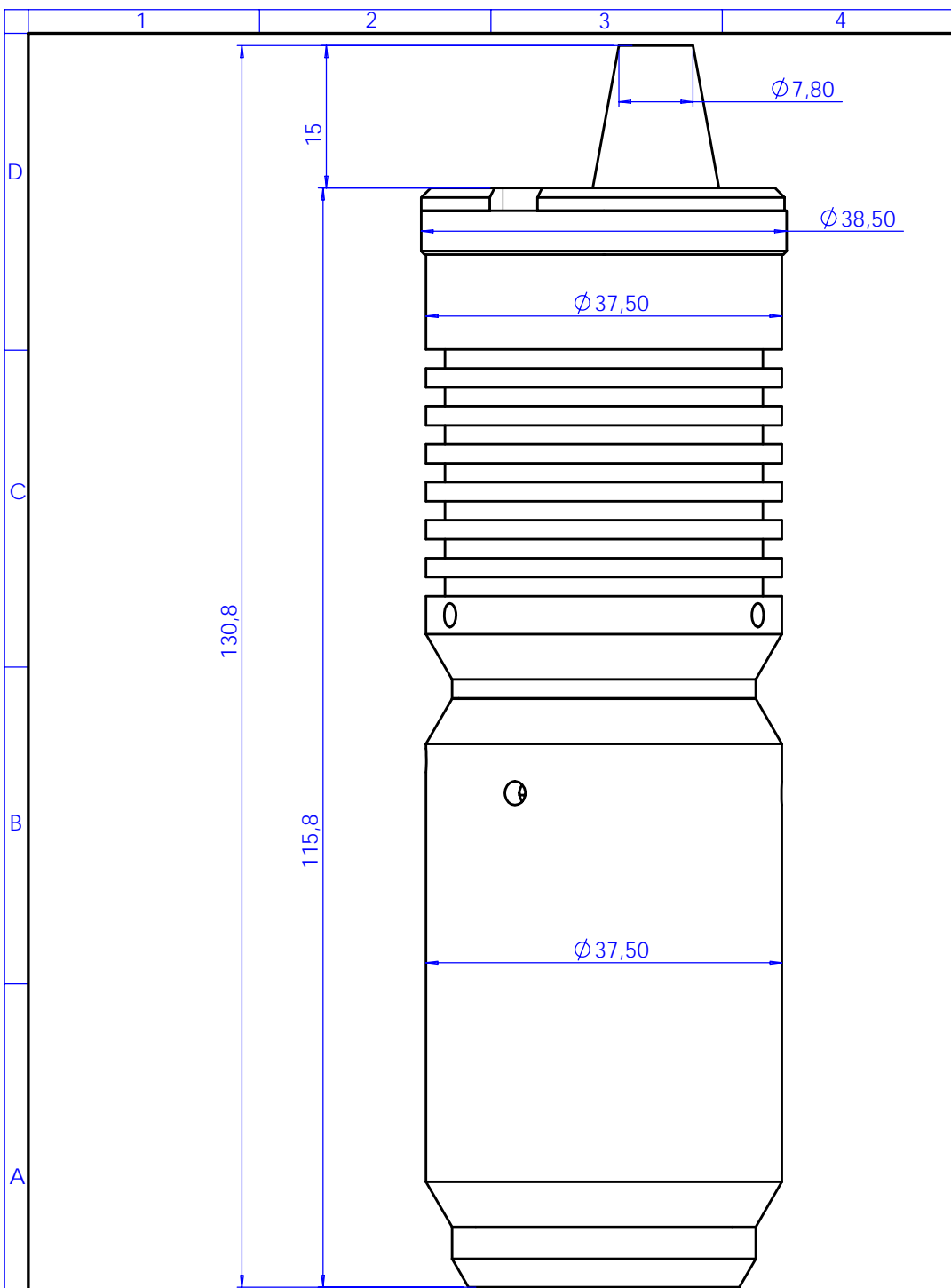

Rev No.	Description	Date	Name
A	Nuovo pezzo	21/03/03	A.Vismara
B	Redesign	05/12/07	A.Vismara

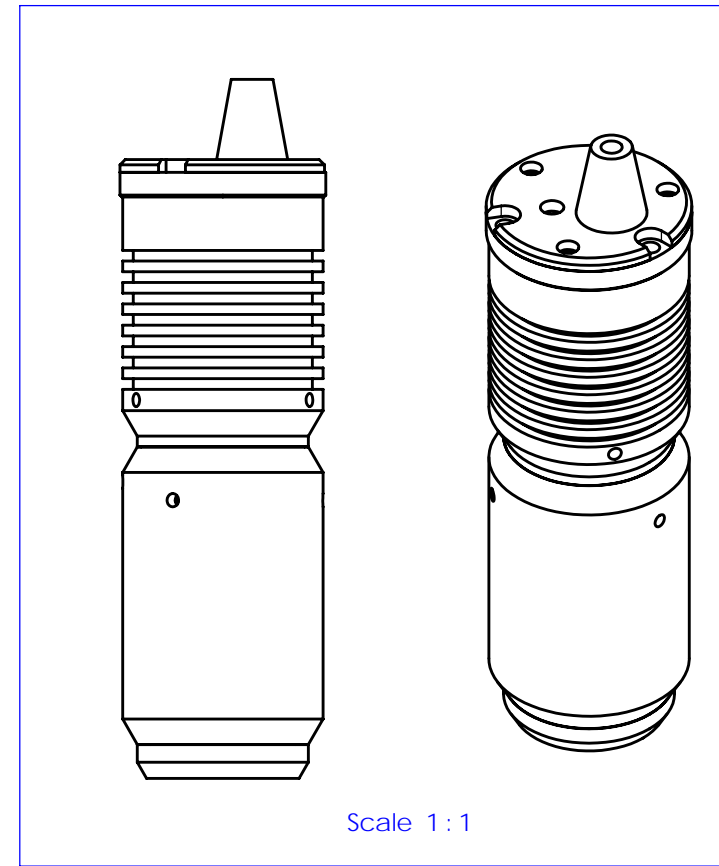

Material	N.A.			Mass	267 g	Scale	2:1
Surface treatment	N.A.			Project-Prod.Item/Instrument		LTSP	
Geometrical tolerance (ISO 2768-2)			Class	K	Description		
Linear tolerance (ISO 2768-2)			Class	m	Undimensioned bevels	1x45°	MECHANICAL LAYOUT
0.5	>3-	>6-	>30-	>120	>400-	>1000	
+3	6	30	120	+400	+1000	+2000	R 0.5
±0.1	±0.1	±0.2	±0.3	±0.5	±0.8	±1.2	±2
www.opto-engineering.com			Date	Name	Drawing No.		
			Designed	17/03/03	A.Vismara	03520-0-B	
			Draw	05/12/07	A.Vismara	1/1	
			Checked	X	C. Sedazzari	Reproduction forbidden without specific authorization	
OPTO ENGINEERING S.r.l. - 46100 Mantova Italy - Via Cremona, 29/2 - Tel. +39 0376 229585 - e-mai: info@opto-engineering.it - http://www.opto-engineering.com							