

LT PR SERIES

LED PATTERN PROJECTOR

STRUCTURED LIGHT MADE EFFICIENT AND FLEXIBLE



WWW.OPTO-ENGINEERING.COM

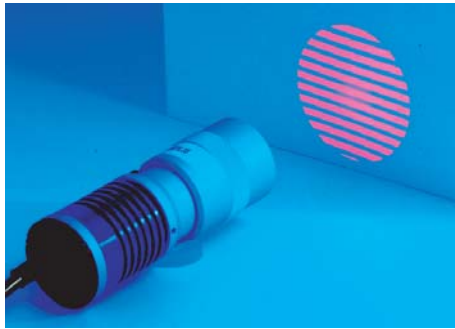



LT PR SERIES are the most advanced and efficient devices for Pattern Projection and Structured Light applications, such as 3D reconstruction.

Unlike Laser Sources, which typically show poor line sharpness and power distribution inhomogeneity as well as scattering and diffraction effects, LT PR overcome all of these problems by integrating LED sources.

Any kind of pattern shape can be easily supplied, integrated and projected.

Different colours, included UV and IR, are available and the size of the projection area can be easily modified by interchanging the projection optics.

UNIQUE OPTICAL FEATURES:

UV  and  IR
versions available

1) PERFECTLY SHARP AND HOMOGENEOUS PROJECTED FEATURES



LT PR SERIES ensures thinner lines, sharper edges and more homogeneous illumination than lasers.



With laser emitters the illumination decays both across the line cross section and along the line width.



Laser emitters lines are thicker and edges blurred; image diffraction and speckle effects are also present.

2) ANY SHAPE CAN BE PROJECTED

LT PR projector can integrate whatever kind of 21 mm (outer) diameter pattern, with an inner active area of 11 mm. Besides off-the-shelf patterns we can easily deliver cost-effective laser engraved patterns or Chrome-on-glass photolithography patterns. The user can easily interchange the pattern unscrewing the retaining ring inside the device.

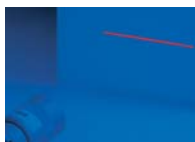

line



crosshair



reticle



stripes



whatever

3) ANY COLOUR AVAILABLE (IR AND UV INCLUDED)

VIS 1W PATTERN PROJECTION UNITS:

LTPR36/R	red light
LTPR36/G	green light
LTPR36/B	blue light
LTPR36/W	white light

VIS 3W PATTERN PROJECTION UNITS:

LTPR3W/R	red light
LTPR3W/W	white light

UV 1W PATTERN PROJECTION UNITS:

LTPR36/UV365	UV, 365 nm
LTPR36/UV385	UV, 385 nm
LTPR36/UV405	UV, 405 nm

IR 1W PATTERN PROJECTION UNITS:

LTPR36/IR890	IR, 890 nm
LTPR36/IR940	IR, 940 nm



LTPR SERIES are available in different colours.



LTPR36/UV365 with projection lens.

SOME EXAMPLES OF SUCCESSFUL APPLICATIONS:



3D reconstruction



Positioning



Visualization and Mapping

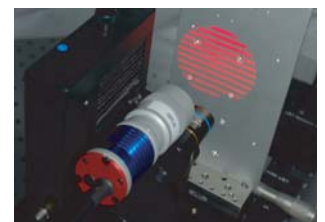

Mechanical alignment

LED TYPICAL SPECTRUM:

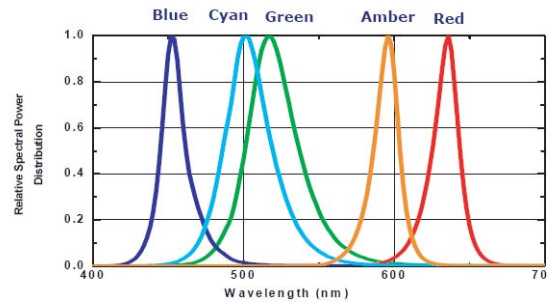
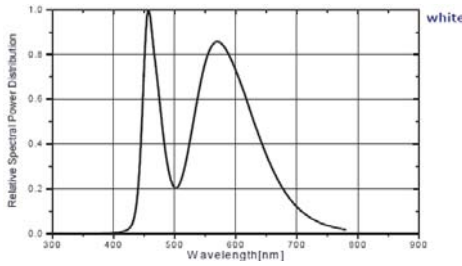

- /UV365 version: peak emission wavelength 365 nm, optical bandpass +/- 20 nm FWHM (class IIIb LED product)
- /UV385 version: peak emission wavelength 385 nm, optical bandpass +/- 20 nm FWHM (class IIIb LED product)
- /UV405 version: peak emission wavelength 405 nm, optical bandpass +/- 30 nm FWHM (class IIIb LED product)
- /IR890 version: peak emission wavelength 890 nm, optical bandpass +/- 30 nm FWHM (class IIIb LED product)
- /IR940 version: peak emission wavelength 940 nm, optical bandpass +/- 30 nm FWHM (class IIIb LED product)

4) ANY KIND OF PROJECTION OPTICS COMPATIBLE

LT PR projectors can integrate specific projection optics as well most kinds of C-mount 2/3" machine vision lenses by means of the C-mount adaptor included in the package. The device can also be interfaced to microscopy systems and to telecentric lenses providing telecentric pattern projection.

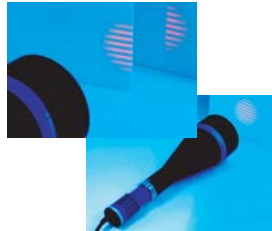

VIS AND IR PROJECTION OPTICS:

- OEPL18 18° projection, full angle
- OEPL25 25° projection, full angle
- OEPL38 38° projection, full angle
- OEPL50 50° projection, full angle

UV PROJECTION OPTICS:

- PEB2528-UV 25° projection, full angle



ELECTRICAL FEATURES:

5) OPTICAL THROUGHPUT IS STABILIZED BY TUNABLE, BUILT-IN ELECTRONICS ...



These LED devices integrate built-in switching electronics which control the current flow through the LED. This ensures both high light stability and a longer lifetime of the product. The device light intensity can be tuned by removing the protection plastic cap in the rear and by screwing or unscrewing the trimmer inside.

- BUILT-IN ELECTRONICS POWER RATINGS:**
- Voltage 12 to 24 V DC
 - Power Consumption < 2 watt

.. BUT YOU CAN PASS-BY INNER ELECTRONICS AND DIRECTLY DRIVE THE LED BY YOURSELF

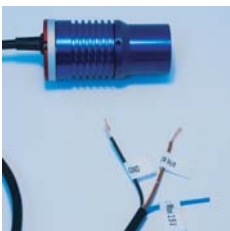

The inner circuitry can be passed-by in order to directly drive the LED inside this device thus allowing pulsed operation of this component.

For this reason, three cables are exiting the rear part of the illuminator. Instead of connecting *black* and *brown* wire leads, the *black* and *blue* wires must be connected to your power supply ensuring the below listed values are not exceeded.

- LED DIRECT DRIVE RATINGS:**
- for /W, /B, /G and /UV versions:
- Max Forward Voltage 3.5 V DC
 - Max Forward Current 350 mA
- for /R version:
- Max Forward Voltage 2.5 V DC
 - Max Forward Current 350 mA

- for /IR890 and /IR940 versions:
- Max Forward Voltage 1.6 V DC
 - Max Forward Current 500 mA

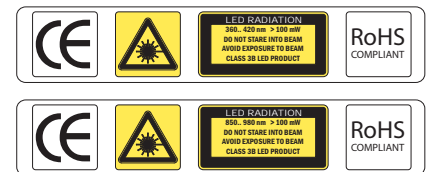

OPTO ENGINEERING S.R.L.

MECHANICAL DRAWINGS: see next page >>

VIA CREMONA, 29/2
46100 MANTOVA - ITALY
TEL: +39 (0)376 263525
FAX: +39(0)376 262432
INFO@OPTO-ENGINEERING.COM
WWW.OPTO-ENGINEERING.COM

SELECTING THE PROJECTION GEOMETRY:

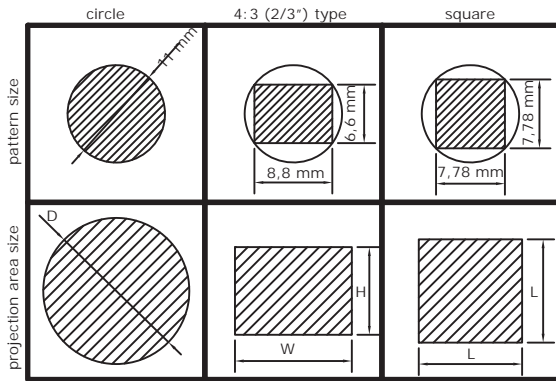

The pattern active area is a circle of 11 mm, therefore the pattern features must be drawn in a rectangle or square inscribed in such a 11 mm diameter circle or inside the entire circle.

The projection area will show the same aspect ratio as the pattern. The main parameter to be calculated is the projection magnification "M", which is the ratio between the pattern dimensions and the projection area. With reference to the right side picture:

$$M = 11/D \quad \text{in case of a circular projection area}$$

$$M = 8,8/W \quad \text{in case of a 4:3 rectangular projection area}$$

$$M = 7,78/L \quad \text{in case of a square projection area.}$$

In order to define the system magnification M and working distance you may proceed as if you would need to image an object whose dimensions are the same as the needed projection area on a 2/3" detector (which exactly features 11 mm diagonal).

You can find indications for the selection of the optics in our Lens and Spacer Selection Chart:

www.opto-engineering.com/brochure/Lens and Spacer Selection Chart.xls

STANDARD PATTERNS:

We offer some standard solutions for patterns. Both laser engraved patterns (P/N ending in "L") and Precision Photolithography patterns (P/N ending in "P") are available:

PHOTOLITHOGRAPHY PATTERNS Substrate: soda lime glass Coating: Chrome Geometrical accuracy: 2 micron Edge Sharpness: < 1 micron	LASER ENGRAVED PATTERNS Substrate: borofloat glass Coating: dichroic mirror Geometrical accuracy: 50 micron Edge Sharpness: < 50 micron
P/N: PT00000100P Line Pattern line thickness = 0.05 mm	P/N: PT00000100L Line Pattern line thickness = 0.5 mm
P/N: PT00000200P Cross Pattern line thickness = 0.05 mm	P/N: PT00000200L Line Pattern line thickness = 0.5 mm
P/N: PT00000300P Stripe Pattern line thickness = 0.05 mm line spacing = 1 mm	P/N: PT00000300L Stripe Pattern line thickness = 0.5 mm line spacing = 1 mm
P/N: PT00000400P Grid Pattern line thickness 0.05 mm line spacing = 1 mm	P/N: PT00000400L Grid Pattern line thickness 0.2 mm line spacing = 1 mm
P/N: PT00000500P Edge Pattern	P/N: PT00000500L Edge Pattern

CUSTOM-MADE PATTERNS:

You can also purchase custom-made pattern suitable for your specific needs.

A .pdf and .dxf file with all the essential geometrical information must be edited and sent us.

Contact us to get a P/N before editing the drawing of any special pattern. Here below please find some instructions for preparing the pattern drawing.

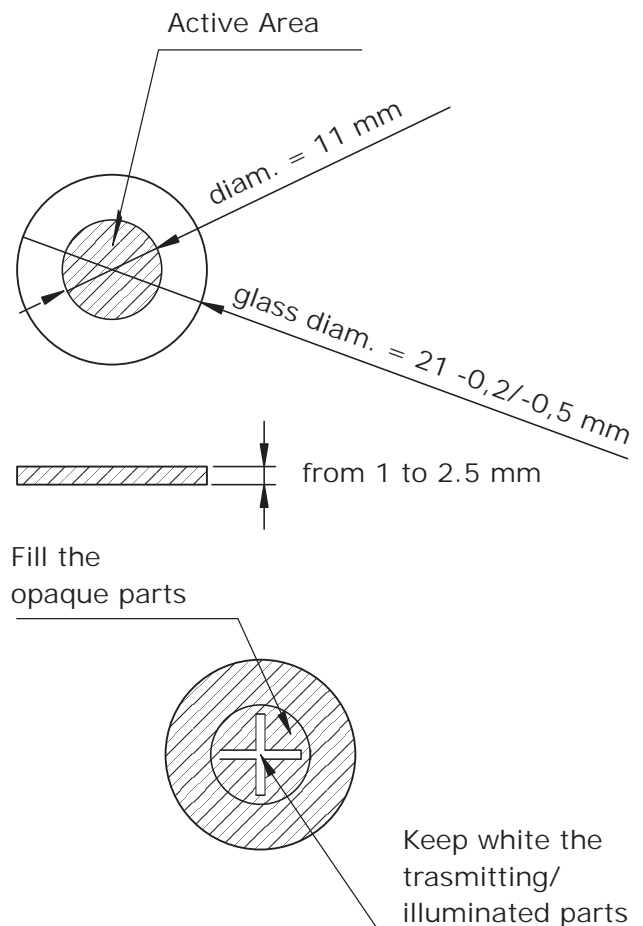

Rev No.	Description	Date	Name
A	Nuovo pezzo	05/12/07	A.Vismara

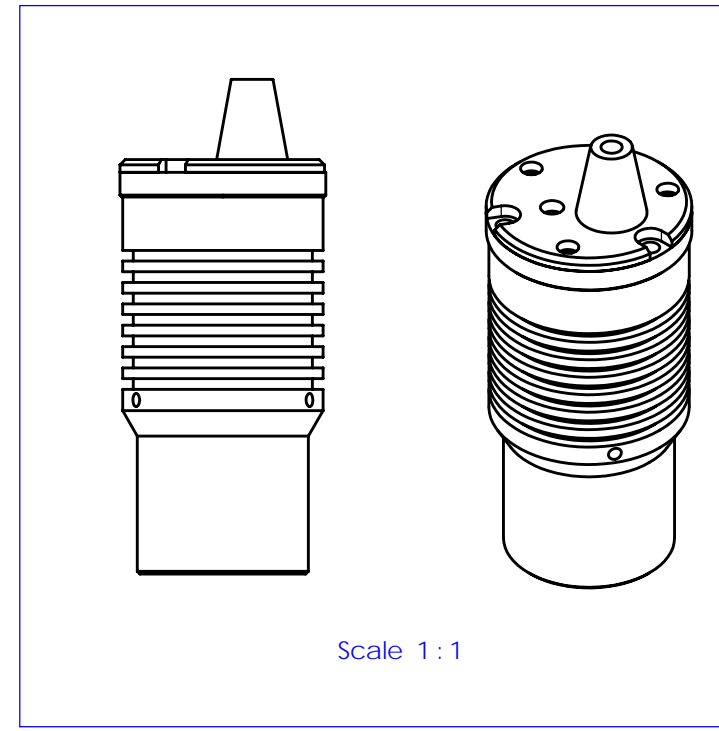
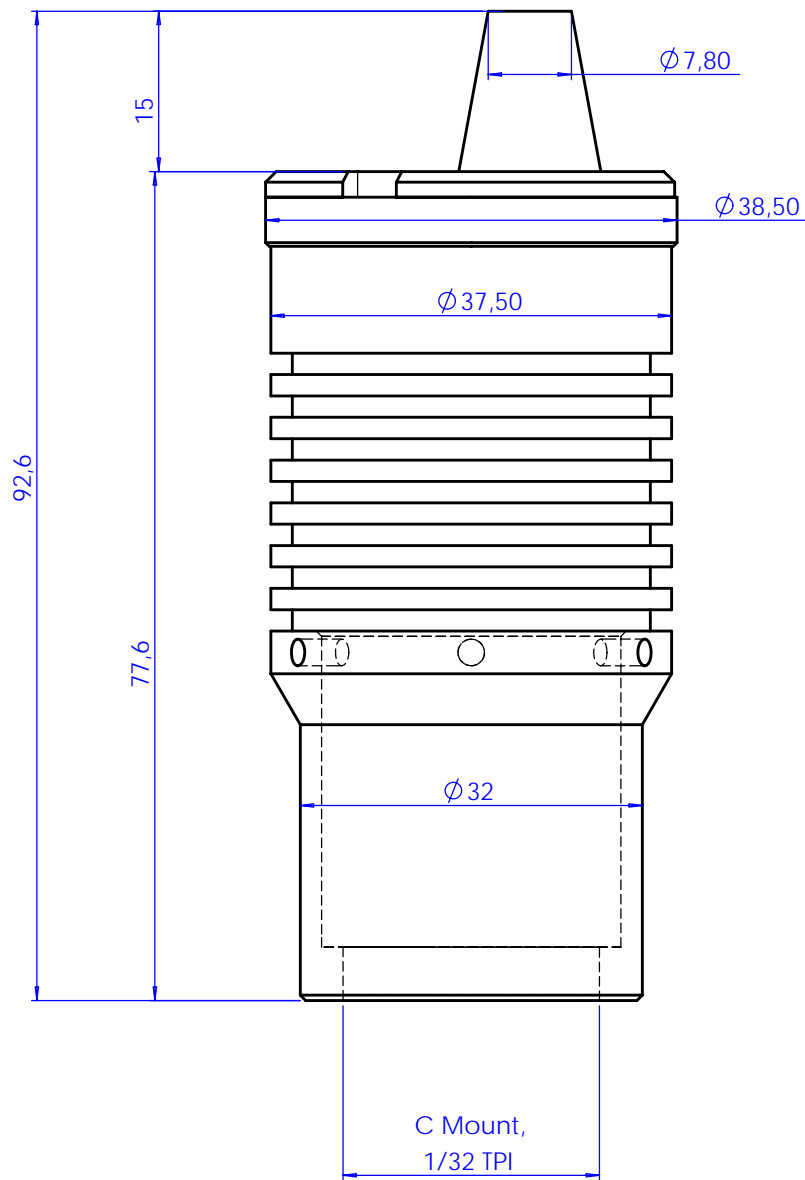

Material	N.A.		Mass	163.8 g	Scale	2:1	
Surface treatment	N.A.		Project-Prod.Item/Instrument	LTPR			
Geometrical tolerance (ISO 2768-2)		Class	K	Undimensioned bevels	1x45°	Description LAYOUT WITH C-MOUNT	
Linear tolerance (ISO 2768-2)		Class	m	Undimensioned radii	R 0.5		
0.5 +3	>3- 6	>6- 30	>30- 120	>120 +400	>400- 1000	>1000 +2000	>2000 +4000
±0.1	±0.1	±0.2	±0.3	±0.5	±0.8	±1.2	±2
www.opto-engineering.com		Date	Name	Drawing No.	Sheet		
		Designed	17/03/03	A.Vismara	03532-0-A	1/1	
		Draw	05/12/07	A.Vismara			
		Checked	X	C. Sedazzari			
<i>Reproduction forbidden without specific authorization</i>							